

NEWCO ENTERPRISES

INSTALLATION, OPERATION, AND SERVICE MANUAL FOR KB SERIES BOTTLED WATER BREWERS



Vessels Not Included

Model	Warmers	Width	Depth	Height	Weight	Watts	Amps
KB-1F	1	9 1/2"	18"	20 1/8"	34	1500	12.5
KB-2F	2	18"	9 1/2"	22 3/8"	39	1600	13.3
KB3-F	3	16 1/2"	18"	20 1/8"	43	1700	14.2
KB-TCF	0	9 1/2"	18"	20 1/8"	34	1400	11.7
KBAPF/LDF*	0	9 1/2"	18"	26 1/2"	42	1400	11.7

*We recommend up to 3 gallon bottles only due to stability, unless anchored to wall.

INSTALLATION INSTRUCTIONS

WARNING – Read and follow installation instructions before plugging or wiring in machine to electrical circuit. Warranty will be void if unit is connected to any voltage other than that specified on the name plate.

FILL BREWER TANK WITH WATER BEFORE CONNECTING TO POWER SUPPLY!

- 1.) Place bottle on top of brewer with neck of bottle extending into receiving hole.
- 2.) Hold faucet open until water flows from it. Allow one minute for automatic leveling of water in tank. Plug or wire brewer to appropriate voltage circuit as indicated on serial tag. Place decanter/carafe/airpot under brew basket and turn lower warmer switch to the "ON" position. Depress brew start switch & check volume of water delivered into decanter/carafe/airpot. Adjust timer to deliver desired amount of water. Turn timer dial clockwise to increase volume of water, and counter clockwise to decrease volume.
- 3.) Allow 10 to 15 minutes for water in tank to heat to brewing temperature. Water has reached brewing temperature when thermostat clicks off and heating noise stops. Green ready light will be lit on models so equipped. Empty vessels and replace.
- 4.) Run one cycle to check for proper temperature setting with an accurate thermometer. Take the temperature of the water at a point below the brew basket opening, at the start of the brew cycle, and when the vessel is half full. Recommended temperature is approximately 195°F.
- 5.) In higher altitudes [5,000 feet above sea level] the thermostat may have to be adjusted to a lower temperature to prevent boiling.
- 6.) **CAUTION:** On faucet models the water faucet will dispense hot water when the handle is depressed. The faucet may be operated during brew cycle.

COFFEE PREPARATION PROCEDURES

- Place filter into brew basket.
- Put the proper amount of coffee into the filter.
- Slide the brew basket into holder.
- On warmer models, place empty decanter on warmer located directly under the brew basket and turn corresponding warmer switch to “ON” position. On thermal models, place dispenser or airpot directly under the brew basket.
- Press brew start switch. [Brew cycle may be canceled by turning the red rocker switch back to the “OFF” position.]
- Hot water will be delivered through the spray head. This distributes the hot water evenly over the coffee grounds within the brew basket. The coffee brew will drain from the brew basket into the decanter below.
- The resultant coffee brew should be crystal clear and have the desired properties attainable through excellent extraction.
- **TURN OFF WARMER WHEN NOT IN USE.** [Illuminated red rocker switch indicates warmer is on.]
- To clean brew basket simply remove from the brew rails and dump coffee filter into waste basket. The brewing process, as described above, can now be started again.
- On units with a “CHANGE BOTTLE” light, this indicator will come on at any time the bottle empties. The bottle should be changed at this time. The brewing circuitry will be disabled until bottled water supply is replenished.

KB SERIES – PARTS LIST

Tanks		Containers	
781178	Tank Assy., KB1F,KB3F,KBAP/LD	100510	12 Cup Glass Decanter [Decaf]
781287	Tank Assy., KB1 & KB3	100550	12 Cup Glass Decanter [Regular]
781219	Tank Assy., KB2F	112005	Thermal Dispenser, 85 oz. [Short]
781287	Tank Assy., KB2	112006	Thermal Dispenser, 85 oz. [Tall]
781217	Receiving Tank/Bracket Assy. without Probe	120795	Airpot, 2.2L Diagonal Lever KK Series
781194	Receiving Tank/Bracket Assy. with Probe	120818	Airpot, 2.2L Stainless Steel Lever KK
102580	Main Element Assy., 1400W 120V	111445	Thermal Server, 1.9L Short Vacuator
111592	Manual Hi-Limit Thermostat, 221F	109115	Thermal Server, 1.9L S/S Coffee Butler
781181	Gasket, Receiving Tank	Miscellaneous Parts	
Warming Plates		102770	Faucet with Red Handle
100008	Plate, Porcelain Black	152114	Deltrol Solenoid Valve
100010	Warming Plate Assy., 100W 120V Black	152130	Valve Repair Kit, Deltrol
100187	Warming Element, 100W 120V	100024	5-hole Spray Head, S/S
Brew Baskets and Rails		100025	Spray Head Gasket
110985	Brew Basket Assy., Black Vac.	201173	Spray Head Nut
110987	Brew Basket Assy., Color Changing Vac.	101365	Timer Only, 25004-4
781030	Right-hand Brew Rail	781195	Liquid Level Board, KB Series
781031	Left-hand Brew Rail	781220	Harness, Tank-SW-Sol-Vio/Wh
		781211	Timer Harness Only
		100022	Power Cord Assy., 14/3 15Amp 120V
		773300	Thermostat Assy., 4.78” Robertshaw
		201985	Start Switch, Momentary Black
		100085	Red Rocker Switch, Lighted
		781212	Ready Light Assy., Green KB series
		201189	Pilot Light with Terminals
		100078	Bumper Foot with Screw

WARRANTY

Applies to all equipment manufactured after 2/1/2017. This warranty supersedes all other previous warranties that are currently in manuals.

- Newco warrants equipment manufactured by it for 1 year parts and labor.
- Accessories and Dispensers 1 Year parts only.
- Electronic Circuit and Control Boards- 3 years parts, 1 year labor.
- Equipment manufactured by others and distributed by Newco- please see original equipment manufacturers warranty, Newco will follow.

These warranty periods run from the date of sale Newco warrants that the equipment manufactured by it will be commercially free of defects in material and workmanship existing at the time of manufacture and appearing within the applicable warranty period. This warranty does not apply to any equipment, component or part that was not manufactured by Newco or that, in Newco's judgment, has been affected by misuse, neglect, alteration, improper installation or operation, relocation or reinstallation, improper maintenance or repair, incorrect voltage applied to the unit at any time, damage or casualty. This warranty does not apply to any equipment failures related to poor water quality, excessive lime and chlorine and non-periodic cleaning and descaling. Warranty is null and void if muriatic or any other form of hydrochloric acid is used for cleaning or deliming. In addition, this warranty does not apply to replacement of items subject to normal use including but not limited to user replaceable parts such as faucet seat cups, sight gauge tubes, washers, o-rings, tubing, seals and gaskets.

This warranty is conditioned on the Buyer 1) giving Newco prompt notice of any claim to be made under this warranty by telephone at (800) 556-3926 or by writing to **3650 New Town Blvd, Saint Charles, MO 63301**; 2) if requested by Newco, shipping the defective equipment prepaid to an authorized Newco service location; and 3) receiving prior authorization from Newco that the defective equipment is under warranty.

THE FOREGOING WARRANTY IS EXCLUSIVE AND IS IN LIEU OF ANY OTHER WARRANTY, WRITTEN OR ORAL, EXPRESS OR IMPLIED, INCLUDING, BUT NOT LIMITED TO, ANY IMPLIED WARRANTY OF EITHER MERCHANTABILITY OR FITNESS FOR A PARTICULAR PURPOSE. The agents, dealers or employees of Newco are not authorized to make modifications to this warranty or to make additional warranties that are binding on Newco. Accordingly, statements by such individuals, whether oral or written, do not constitute warranties and should not be relied upon.

If Newco determines in its sole discretion that the equipment does not conform to the warranty, Newco, at its exclusive option while the equipment is under warranty, shall either 1) provide at no charge replacement parts and/or labor (during the applicable parts and labor warranty periods specified above) to repair the defective components, provided that this repair is done by a Newco Authorized Service Representative; or 2) shall replace the equipment or refund the purchase price for the equipment.

THE BUYER'S REMEDY AGAINST NEWCO FOR THE BREACH OF ANY OBLIGATION ARISING OUT OF THE SALE OF THIS EQUIPMENT, WHETHER DERIVED FROM WARRANTY OR OTHERWISE, SHALL BE LIMITED, AT NEWCO'S SOLE OPTION AS SPECIFIED HEREIN, TO REPAIR, REPLACEMENT OR REFUND.

In no event shall Newco be liable for any other damage or loss, including, but not limited to, lost profits, lost sales, loss of use of equipment, claims of Buyer's customers, cost of capital, cost of down time, cost of substitute equipment, facilities or services, or any other special, incidental or consequential damages.

TROUBLE SHOOTING GUIDE

SYMPTOM	POSSIBLE CAUSE	WHAT TO CHECK	REMEDY
CAN'T START BREW CYCLE	<ol style="list-style-type: none"> 1. No Water 2. No Power 3. On/Off Switch 4. Brew Start Switch 5. Timer/Timer Harness 6. Solenoid Valve 	<ol style="list-style-type: none"> 1. Water bottle is empty? 2. Fuse or circuit breaker, power cord & plug connections 3. Switch continuity [normally closed 1 & 2] 4. Switch continuity [normally open] 5. Leads to solenoid, switches, & level sensor probe. 6. (A) Voltage at solenoid valve terminals, start a brew cycle & check for 120V AC (B) If voltage is present at terminals, check water on the inlet side of solenoid valve 	<ol style="list-style-type: none"> 1. Replace empty bottle with new one 2. Replace or reset circuit protector as required, unit should be plugged in securely 3. If On/Off switch does not make and break contact replace it 4. If brew start switch does not make & break contact, replace it 5. Make sure these connections are tight, if all checks out ok replace timer 6. (A) If voltage is not present at terminals, refer to steps 2 thru 5 (B) If voltage is present at terminals, water is present at the inlet side but not at the outlet side of the solenoid valve replace it
NO HOT WATER	<ol style="list-style-type: none"> 1. Tank heater 2. Hi-limit thermostat or main thermostat 	<ol style="list-style-type: none"> 1. Check voltage at the tank terminals, voltage should be as indicted on the serial tag 2. Check voltage between the white wire on the tank & incoming terminal [blue wire] on the hi-limit thermostat, then the outgoing terminal [black wire] on the hi-limit thermostat 	<ol style="list-style-type: none"> 1. (A) If correct voltage is present at the tank heater terminals & water not heated, replace the tank's heating element (B) If voltage is not present at the tank heater terminals refer to step 2 (c) if incorrect voltage is present at the tank heater terminals, check voltage at outlet 2. (A) If voltage is present on the incoming terminal of the hi-limit thermostat, but not on the outgoing terminal, replace the hi-limit thermostat (B) Check the voltage between the black & white wire on the receptacle, if voltage is not present check outlet or circuit breaker (C) If voltage is not present on the incoming terminal of the hi-limit thermostat replace the main the main thermostat
STEAMING/SPITTING AROUND FUNNEL	<ol style="list-style-type: none"> 1. Main Thermostat 2. High Altitude 	<ol style="list-style-type: none"> 1. Thermostat points stuck or out calibration 2. Located above 5,000 feet 	<ol style="list-style-type: none"> 1. (A) Adjust thermostat (B) Thermostat should be calibrated or replace 2. See installation instructions
FAUCET WATER TOO SLOW	<ol style="list-style-type: none"> 1. No Water 	<ol style="list-style-type: none"> 1. (A) Water bottle (B) Faucet clogging 	<ol style="list-style-type: none"> 1. (A) Replace empty bottle with new one (B) Clean or rebuild faucet
DRIPPING	<ol style="list-style-type: none"> 1. Not siphoning properly 	<ol style="list-style-type: none"> 1. Water should flow freely from the spray head 	<ol style="list-style-type: none"> 1. (A) Clean spray head holes (B) Check tightness of spray head tube
DRY COFFEE REMAINING IN BREW BASKET AFTER BREWING	<ol style="list-style-type: none"> 1. Filter 2. Not siphoning properly 3. Improper loading of brew basket 	<ol style="list-style-type: none"> 1. Correct filters being used? 2. Refer to "Dripping" step 1 3. Filter & coffee in brew basket 	<ol style="list-style-type: none"> 1. Insert proper filter 2. Refer to "Dripping" step 1 3. Filter centered, coffee bed level

TROUBLE SHOOTING GUIDE

SYMPTOM	POSSIBLE CAUSE	WHAT TO CHECK	REMEDY
WEAK COFFEE	<ol style="list-style-type: none"> 1. Filters 2. Not siphoning properly 3. Improper loading of brew basket 	<ol style="list-style-type: none"> 1. Are the correct filters being used? 2. Refer to "Dripping" step 1 3. Filter & coffee in brew basket 	<ol style="list-style-type: none"> 1. Insert correct filter 2. Refer to "DRIPPING" step 1 3. Filter centered, coffee bed level
COLD WARMER STATION	<ol style="list-style-type: none"> 1. Warmer – defective 2. Warmer ON/OFF switch 3. Bad harness 	<ol style="list-style-type: none"> 1. Voltage at warmer terminals should be 120V AC 2. If voltage is not present on warmer terminals check continuity of switch 3. Check connections between harness & switch, and between switch & warmer 	<ol style="list-style-type: none"> 1. If voltage is present on terminals, but warmer will not heat, replace warmer 2. If switch does not make & break continuity when turned off, replace switch 3. All connections should be tight
CONDENSATION ON THE INSIDE OF CABINET	<ol style="list-style-type: none"> 1. Tank lid gasket 2. Spray head tube assy. 3. Thermostat grommet 4. Receiving pan nut 5. Main thermostat set above 201°F 	<ol style="list-style-type: none"> 1. Nicks or cuts in the gasket 2. Tightness of assembly to lid 3. Tight fit, nicks, or cuts 4. Receiving pan nut loose 5. Check thermostat calibration 	<ol style="list-style-type: none"> 1. Replace gasket 2. Tighten spray head tube assy. to tank lid 3. Adjust or replace grommet 4. Tighten nut 5. Calibrate or replace thermostat
WATER KEEPS RUNNING	<ol style="list-style-type: none"> 1. 1.Solenoid Valve 2. Start Switch 3. Timer 	<ol style="list-style-type: none"> 1. Refer to "DRIPPING" step 1 2. Remove wires from switch & check continuity 3. Solid state timers are not repairable, if timer will not shut off, replace timer 	<ol style="list-style-type: none"> 1. Refer to "DRIPPING" step 1 2. If start switch does not make or break contact, switch should be replaced 3. Replace timer

WIRING DIAGRAM

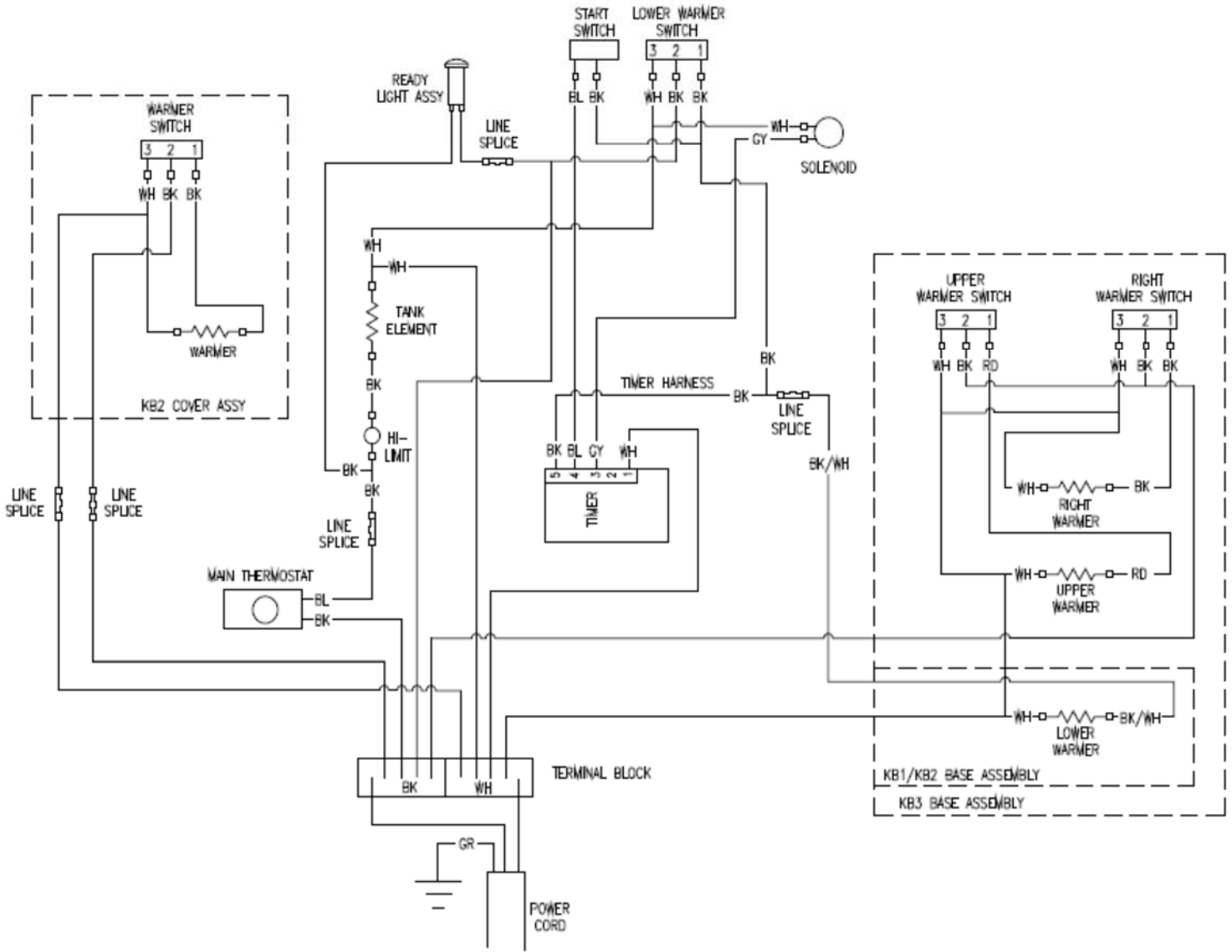

NOTES

NOTES